

VP-Series

VP-1100/1500
Vertical Machining Center



CF-0512106
RPM10000

RIGID CONSTRUCTION

*INNOVATIVE DESIGN ·
SUPERIOR PRODUCTIVITY*

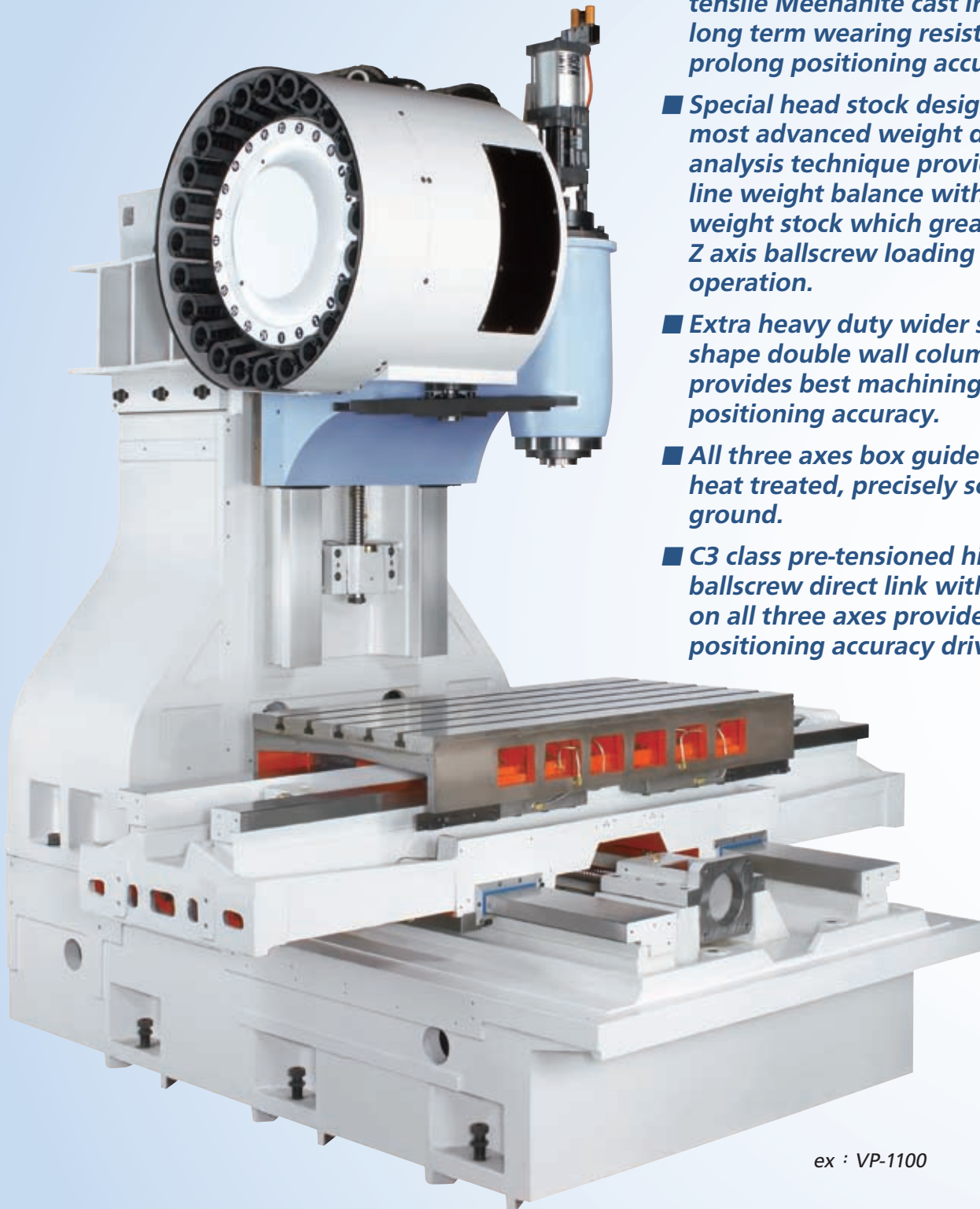

- *All major parts are built with high tensile Meehanite cast iron, featuring long term wearing resistance and prolong positioning accuracy.*
- *Special head stock design with the most advanced weight distribution analysis technique provides best in line weight balance with counter weight stock which greatly reduced Z axis ballscrew loading during operation.*
- *Extra heavy duty wider span Y shape double wall column design provides best machining rigidity and positioning accuracy.*
- *All three axes box guide ways are heat treated, precisely scraped and ground.*
- *C3 class pre-tensioned high precision ballscrew direct link with servomotor on all three axes provides high positioning accuracy driven.*

ex : VP-1100

INNOVATIVE HEAD STOCK DESIGN

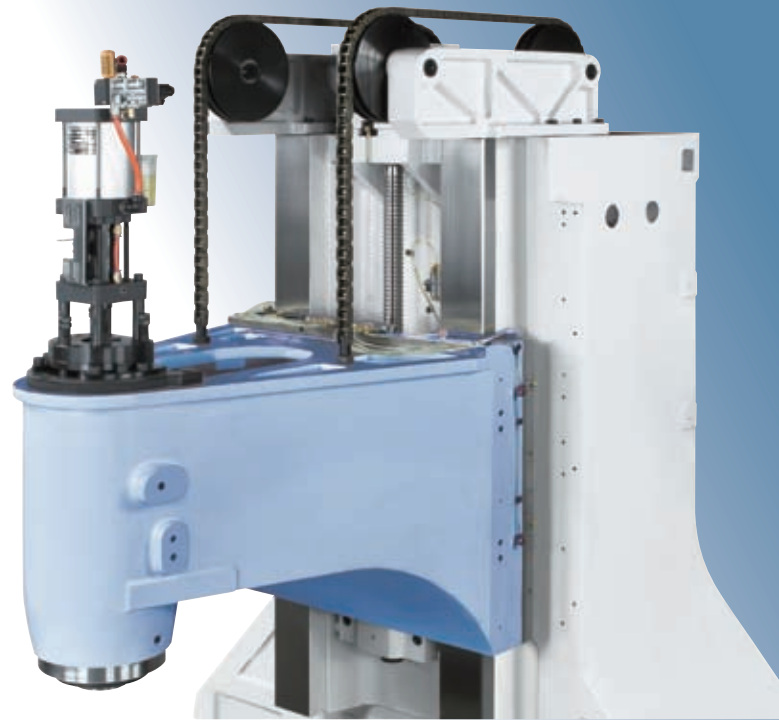
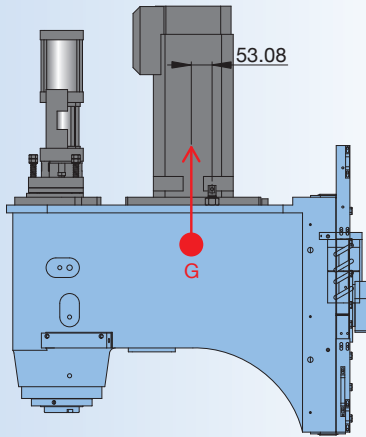

- Tri-angle design head stock provides best stability and flexibility on Z axis movement during operation.
- Floating tool clamp/unclamp system prevent spindle bearing from impacting during tool exchange.

HIGH RIGIDITY BASE DESIGN

- *Extra wide distance between guide ways design provides best stability and accurate operation.*
- *Advanced coolant and oil separated design prolongs coolant quality.*
- *All bearing housings are ground and precisely scrapped to provide higher accuracy and prolong ballscrews durability.*
- *VP-1500 model featured with steel roller bearing on supporting guide ways provides best combination of stability and flexibility during operation.*

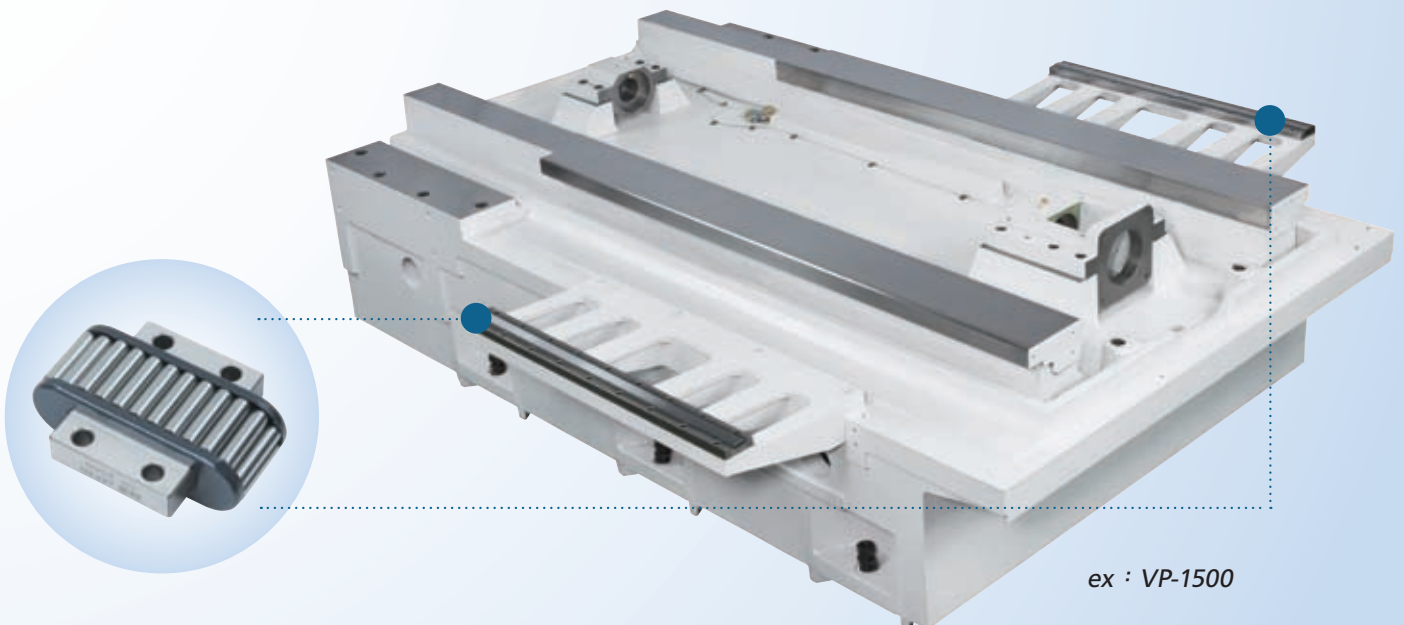



HIGH MACHINING CAPACITY DESIGN SPINDLE

- 70 mm P4 class angular contact bearings and large span design largely promote the spindle rigidity and cutting ability.
- Special spindle nose design with Labyrinth and air curtain prevents coolant and chips damage.

SPINDLE MOTOR TORSION DRAWING

Fanuc

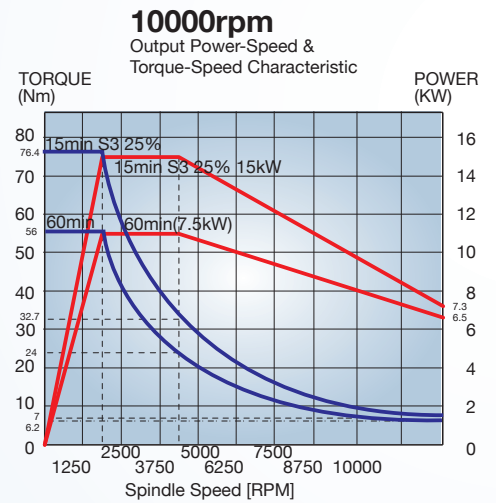
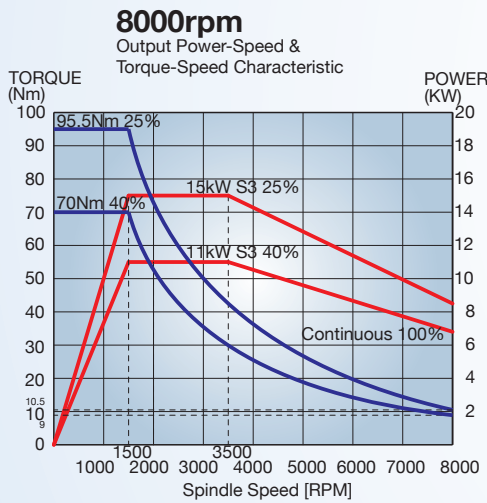
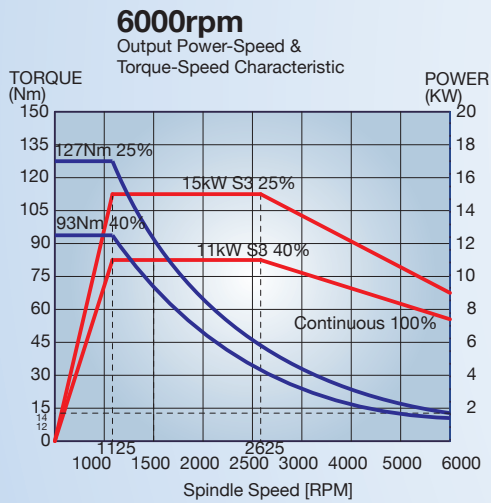

Mitsubishi

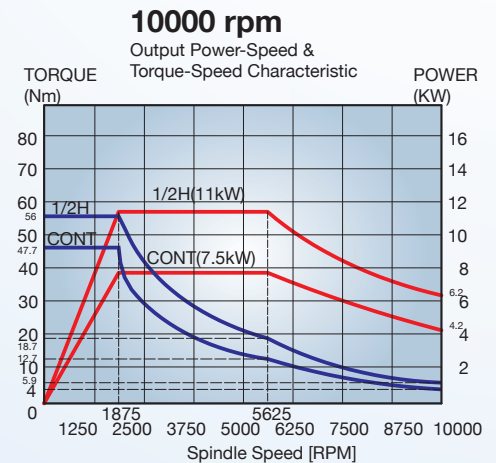
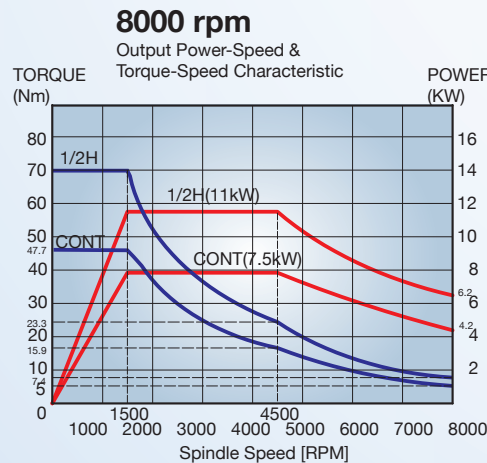
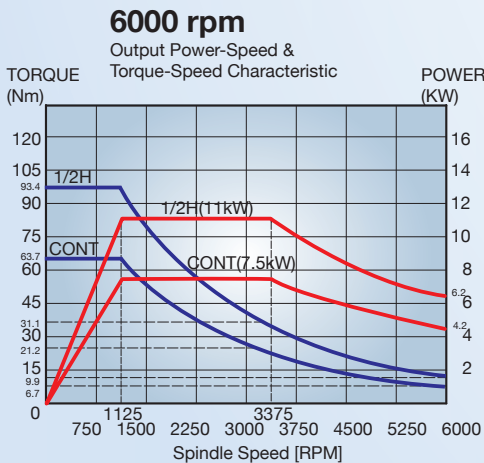

PULL STUD & TOOL SHANK DRAWING

Tool shank BT50

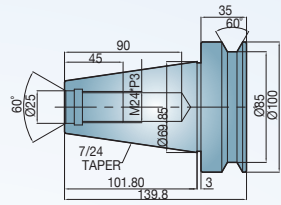

MAS-P50T-1

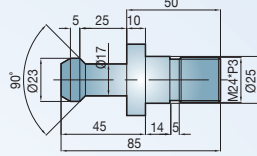

CAT50

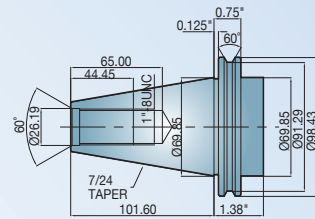

ANSI CAT50

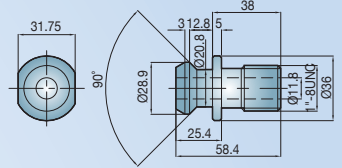

Tool shank BT40

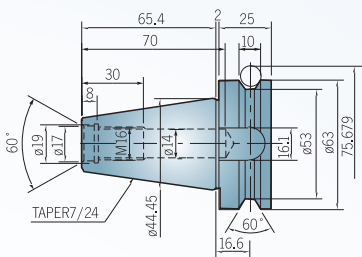

MAS-P40T-1

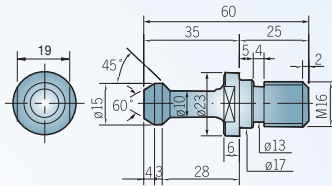

CAT40

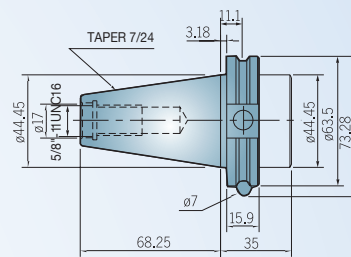

ANSI CAT40

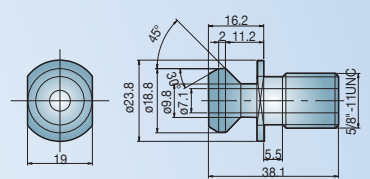

MACHINE FEATURE

24 tools arm type ATC system (Standard)

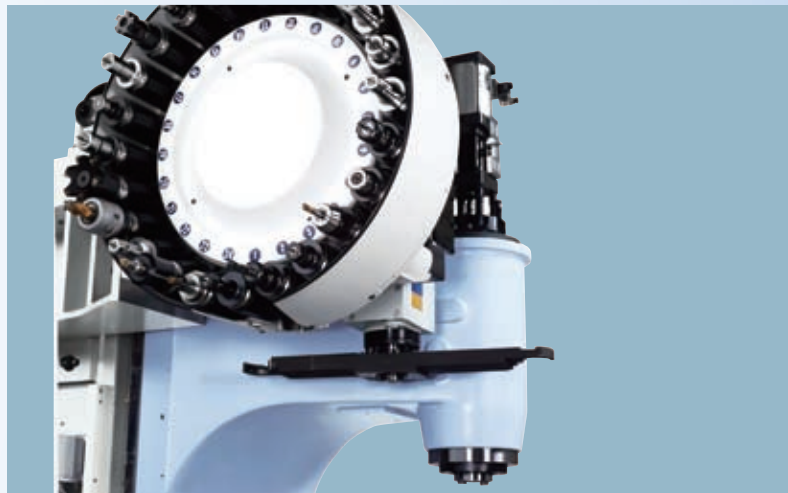

Chip flush system (Optional)

Flush nozzles provide at both side of splash guard, efficiently remove chips during operation.

Chain type chip conveyor (Optional)



CUTTING ABILITY

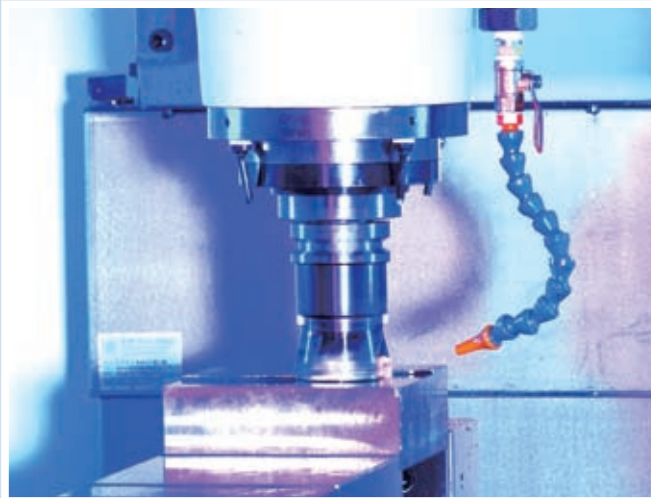

FACE MILLING

Work piece material	S50C
Spindle speed	920 RPM
Feedrate	1380 mm/min
Cutting width	90 mm
Cutting depth	3 mm
Material elimination rate	373 cc/min

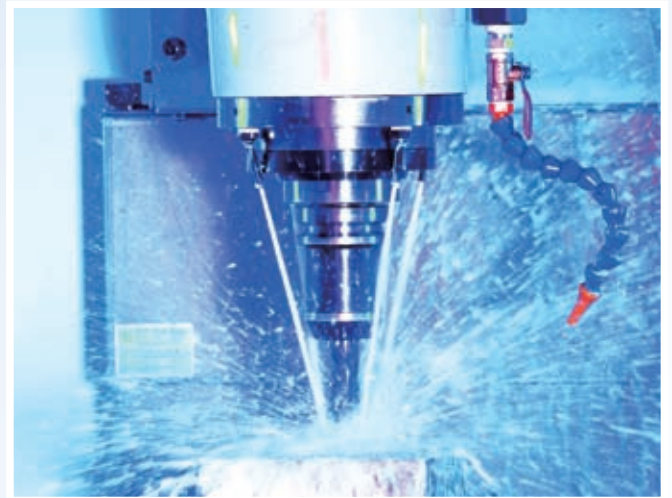

END MILLING

Work piece material	S50C
Spindle speed	800 RPM
Feedrate	200 mm/min
Cutting width	6 mm
Cutting depth	45 mm
Material elimination rate	54 cc/min

WORK PIECE SAMPLE

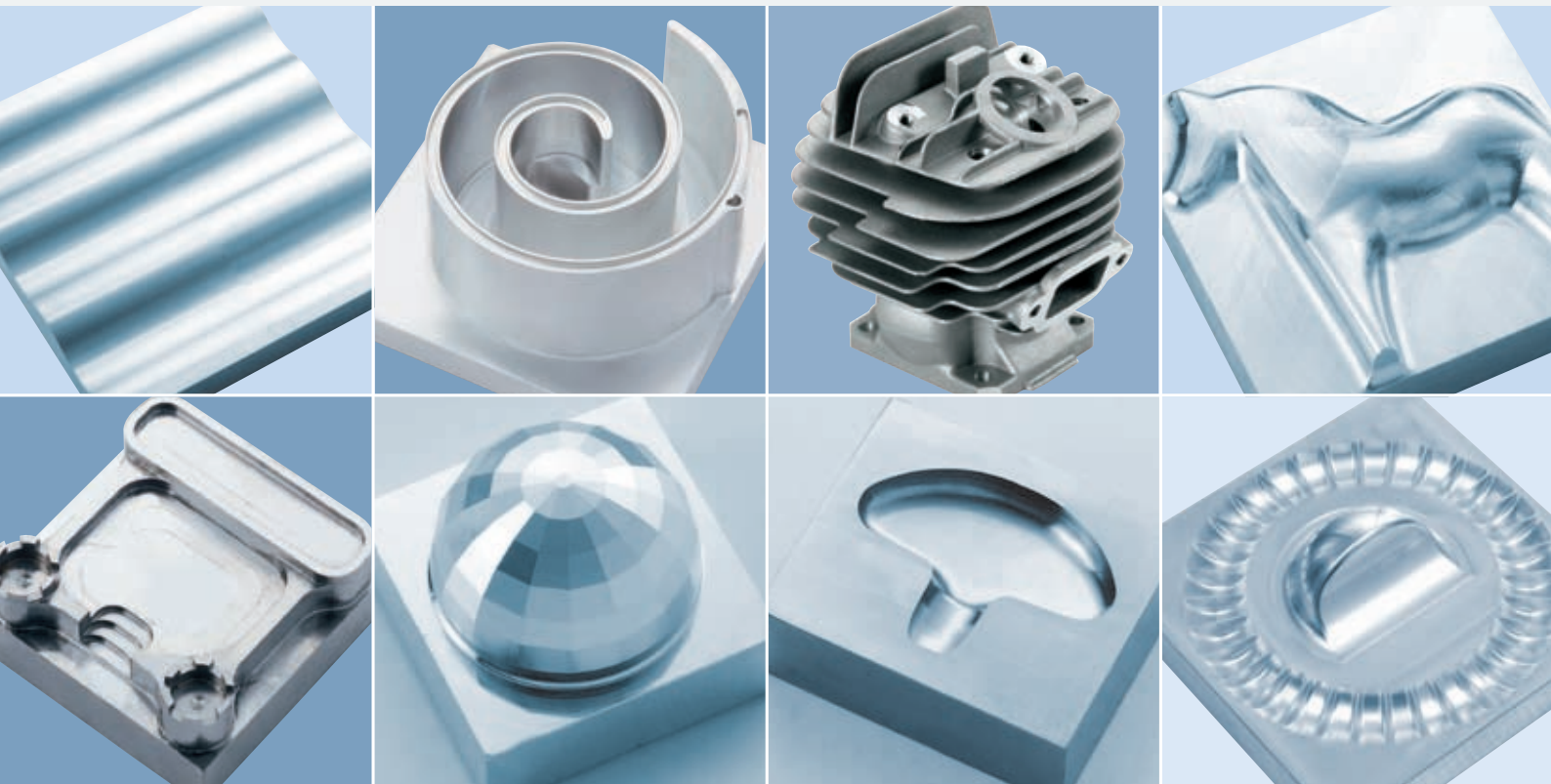

DIMENSIONAL DRAWING

Unit:mm

VP Series

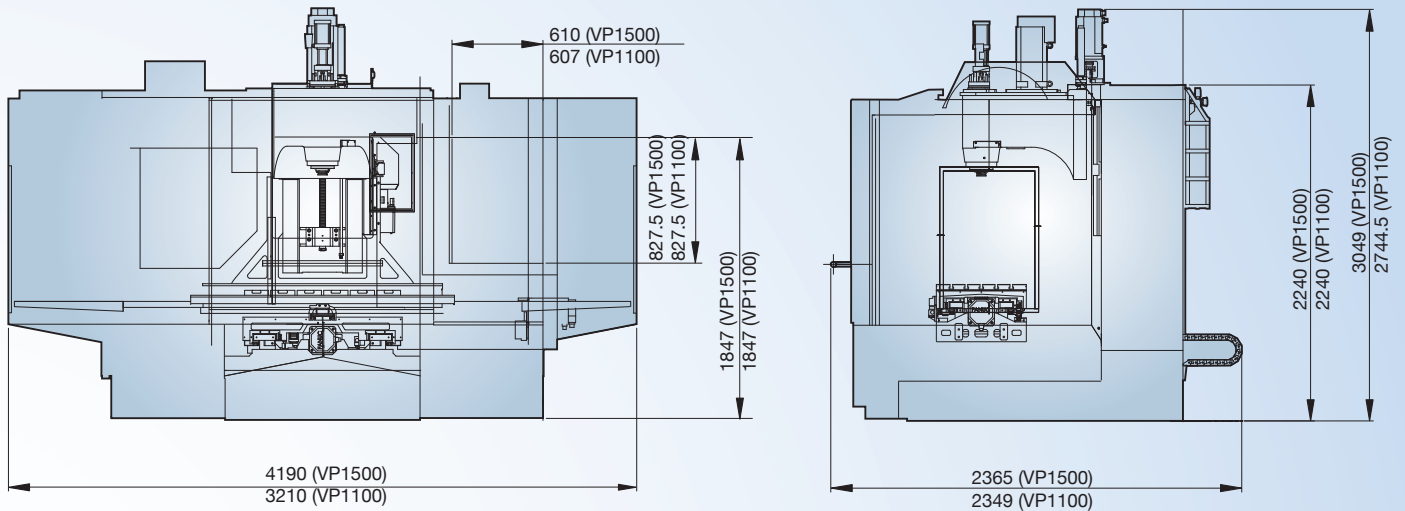

VP Plus Series (Y-Axis travels 700mm)

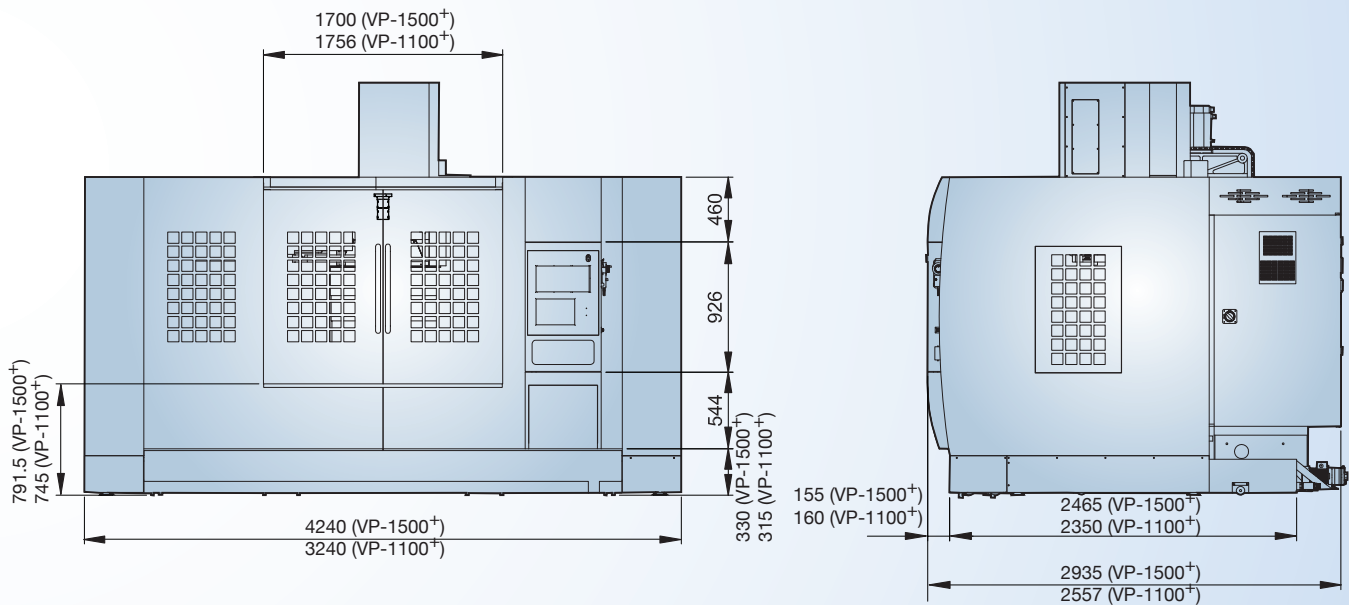

WORK TABLE DIMENSIONAL DRAWING

Unit:mm

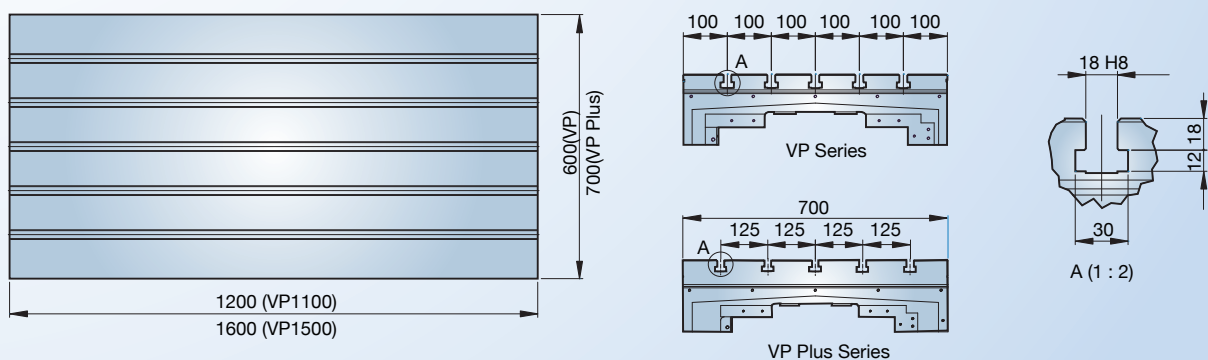

MACHINE SPECIFICATION

	VP-1100	VP-1100 ⁺	VP-1500	VP-1500 ⁺
TRAVELS				
X Axis	1100 mm		1500 mm	
Y Axis	600 mm	700 mm	600 mm	700 mm
Z Axis	600 mm			
Spindle Nose To Table Surface	150 - 750 mm			
Spindle Center To Column Front	660 mm			
Column Rail Face To Table Center	350 - 950 mm			
FEEDRATE				
Rapid Feedrate X & Y Axis	20 m/min	20 m/min	16 m/min	16 m/min
Rapid Feedrate Z Axis	20 m/min	20 m/min	16 m/min	16 m/min
Cutting Feedrate	8 m/min	8 m/min	8 m/min	8 m/min
TABLE				
Table Size	1200 x 600 mm	1200 x 700 mm	1600 x 600 mm	1600 x 700 mm
Max. Load Permissible	800 kgs			
T-Slot Number	5			
T-Slot Pitch	100 mm (VP) / 125 mm (VP+)			
T-Slot Width	18 mm			
HEAD STOCK				
Spindle Speed	8000 rpm			
Spindle Diameter	Ø70 mm			
Spindle Taper	BT-40 / CAT-40			
Spindle Motor	11 / 15 kW (Fanuc) , 7.5 / 11 kW (Mitsubishi)			
ATC				
Max. Tool Diameter(With Adj. Tool)	Ø80 mm			
Max. Tool Diameter	Ø125 mm			
Max. Tool Length	300 mm			
Max. Tool Weight	7 kgs			
GENERAL INFORMATION				
Machine Weight (Approx.)	8800 kgs	9300 kgs	9000 kgs	12000 kgs
Machine Height	2730 mm	2930 mm	2730 mm	2930 mm
Floor Space (WxDxH)	3210 x 2360 mm	3240 x 2560 mm	4170 x 2900 mm	4300 x 2935 mm
Positioning	0.005 / 300 mm			
Repeatability	±0.003 mm			
Air Pressure Required	6 kgs/cm ²			

Remark : Specification and design characteristics subject to change without prior notice.

STANDARD FEATURE

- Coolant system
- Arm type 24T ATC
- Rigid tapping
- Automatic Oil Lubricator
- Work lamp
- Heat exchanger for electrical cabinet
- Automatic power off (M30)
- Remote MPG
- Adjustment tools & tool box
- Enclosed splash guard
- Leveling bolts and pads
- Spindle air blast
- Work air blast
- RS-232 interface
- Fanuc Oi-MD or Mitsubishi M70

OPTIONAL FEATURE

- Y axis Travels 700mm
- Spindle speed 6000rpm (BT-50)
- Spindle speed 10000rpm (BT-40)
- ZF Gear box
- Coolant through spindle with filter system
- Wide range motor
- 4th axis rotary table
- Chain type chip conveyor with cart
- Spiral type chip conveyor with cart
- Transformer
- CE Specification
- Fanuc 31i-MB
- Mitsubishi M700 series
- Siemens 802D SL / 828D / 840D SL

Twinhorn[®]

CHI-FA MACHINERY MANUFACTURER CO., LTD.

NO.44-8 MING-CHUNG RD., SHENG KANG DIST.,

TAICHUNG CITY, TAIWAN

TEL:+886-4-25628747

FAX:+886-4-25614199

<http://www.twinhorn.com>

E-mail: inquiry@twinhorn.com.tw

CF-0512106
RPM10000

RIGID CONSTRUCTION

*INNOVATIVE DESIGN ·
SUPERIOR PRODUCTIVITY*

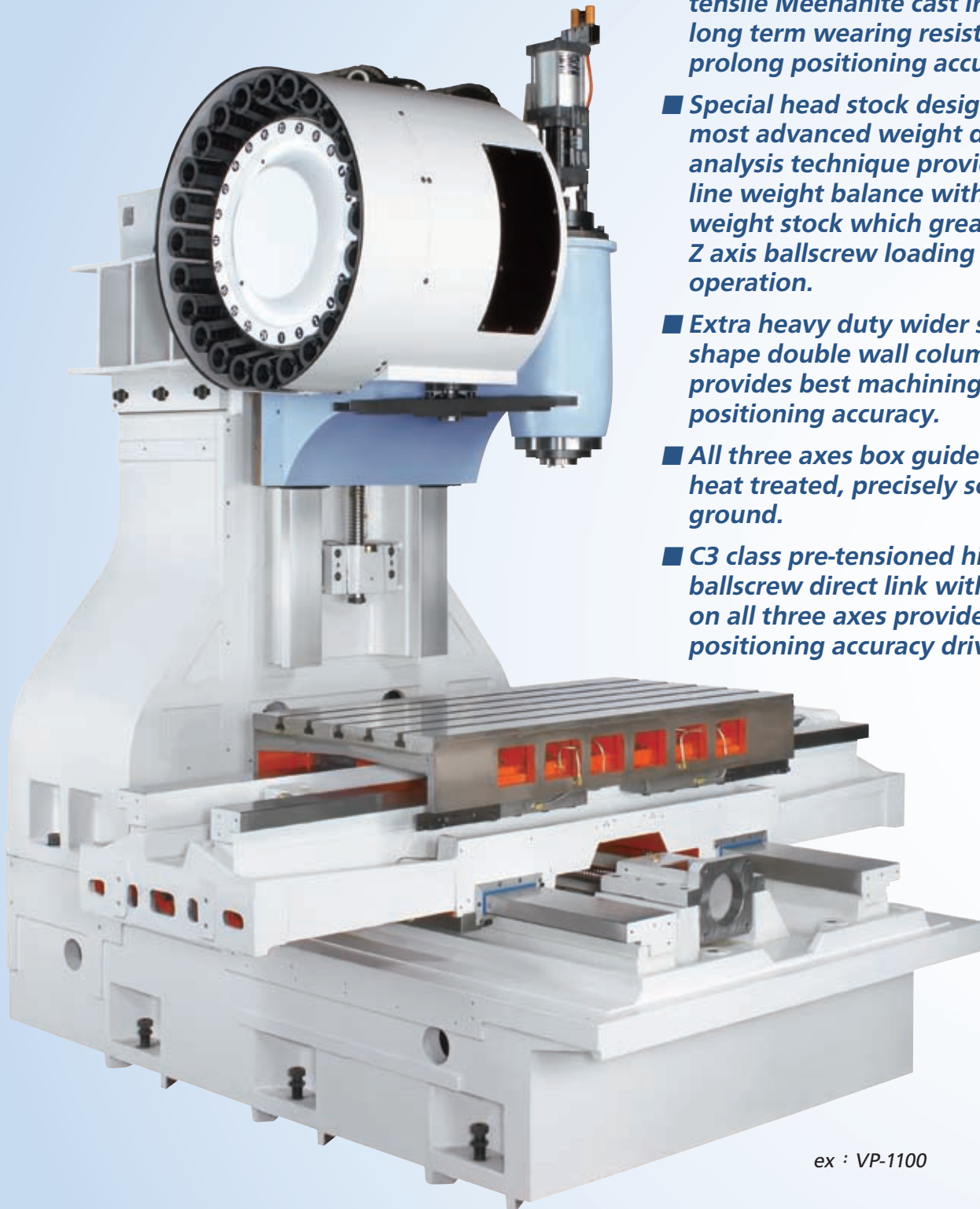

- *All major parts are built with high tensile Meehanite cast iron, featuring long term wearing resistance and prolong positioning accuracy.*
- *Special head stock design with the most advanced weight distribution analysis technique provides best in line weight balance with counter weight stock which greatly reduced Z axis ballscrew loading during operation.*
- *Extra heavy duty wider span Y shape double wall column design provides best machining rigidity and positioning accuracy.*
- *All three axes box guide ways are heat treated, precisely scraped and ground.*
- *C3 class pre-tensioned high precision ballscrew direct link with servomotor on all three axes provides high positioning accuracy driven.*

ex : VP-1100

INNOVATIVE HEAD STOCK DESIGN

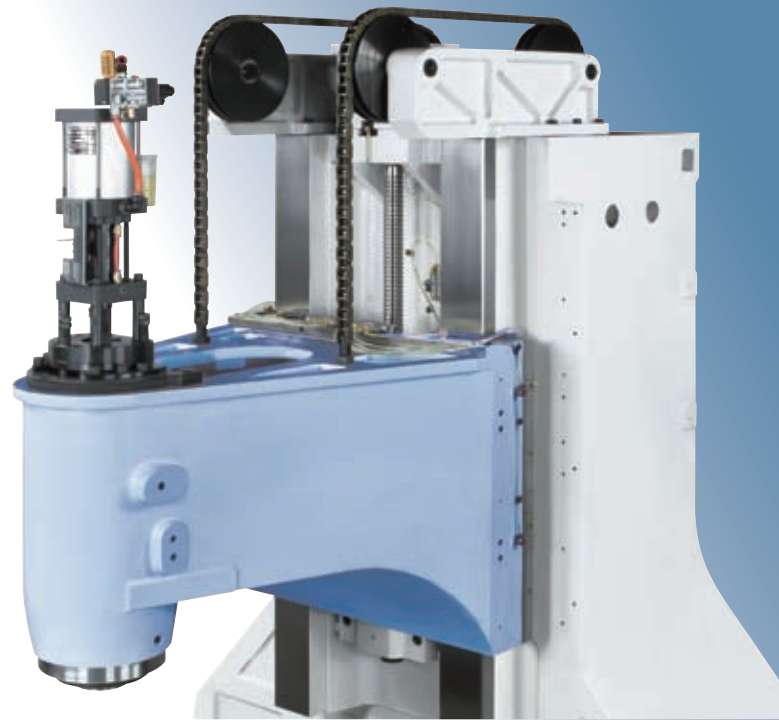
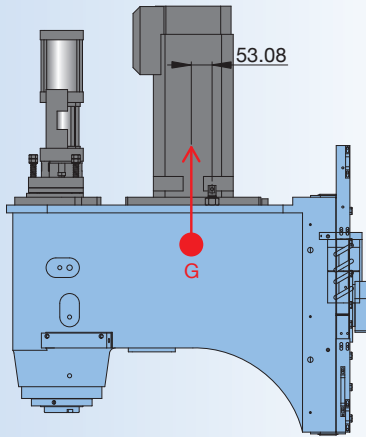

- Tri-angle design head stock provides best stability and flexibility on Z axis movement during operation.
- Floating tool clamp/unclamp system prevent spindle bearing from impacting during tool exchange.

HIGH RIGIDITY BASE DESIGN

- *Extra wide distance between guide ways design provides best stability and accurate operation.*
- *Advanced coolant and oil separated design prolongs coolant quality.*
- *All bearing housings are ground and precisely scrapped to provide higher accuracy and prolong ballscrews durability.*
- *VP-1500 model featured with steel roller bearing on supporting guide ways provides best combination of stability and flexibility during operation.*

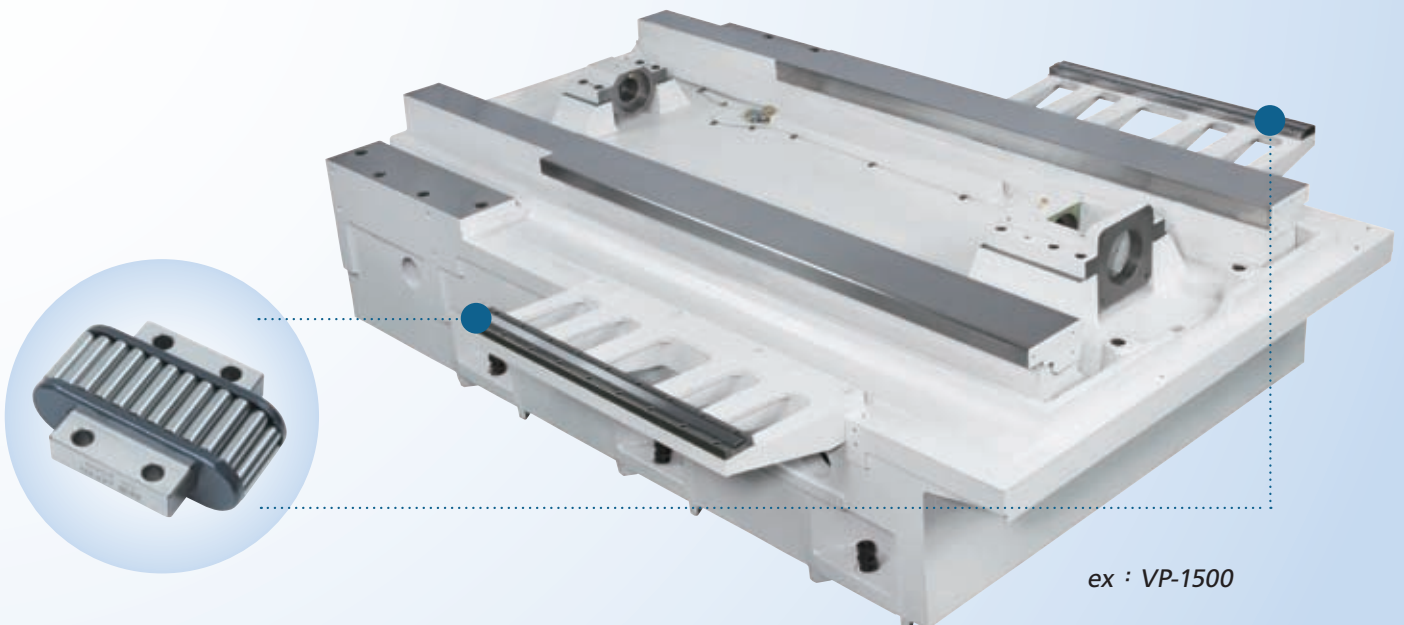

ex : VP-1500



HIGH MACHINING CAPACITY DESIGN SPINDLE

- 70 mm P4 class angular contact bearings and large span design largely promote the spindle rigidity and cutting ability.
- Special spindle nose design with Labyrinth and air curtain prevents coolant and chips damage.

SPINDLE MOTOR TORSION DRAWING

Fanuc

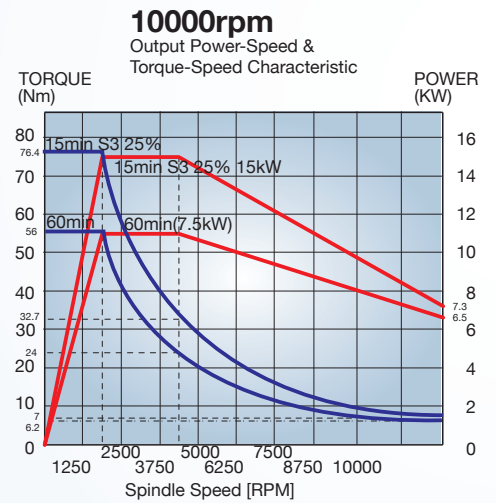
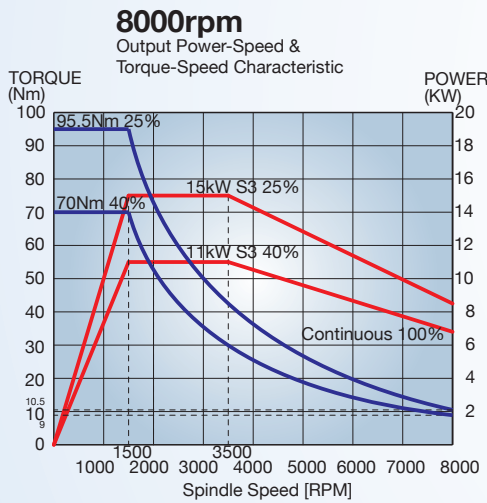
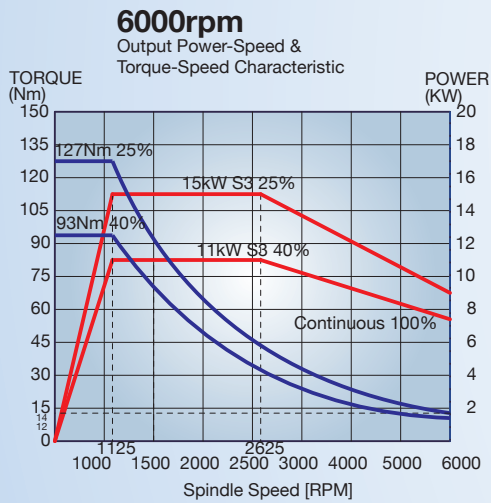

Mitsubishi

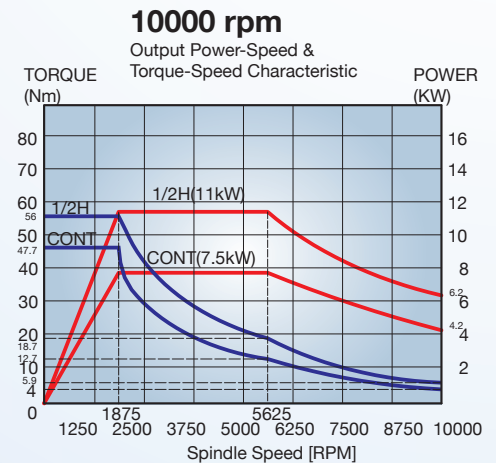
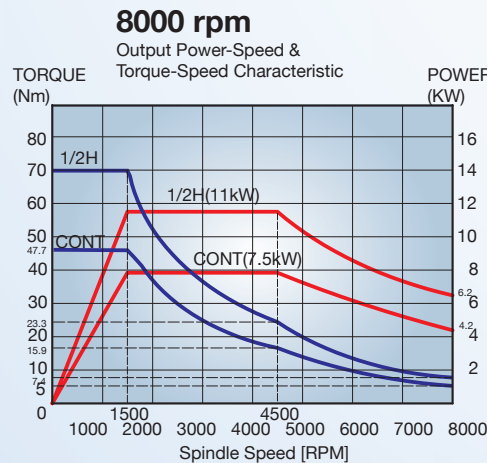
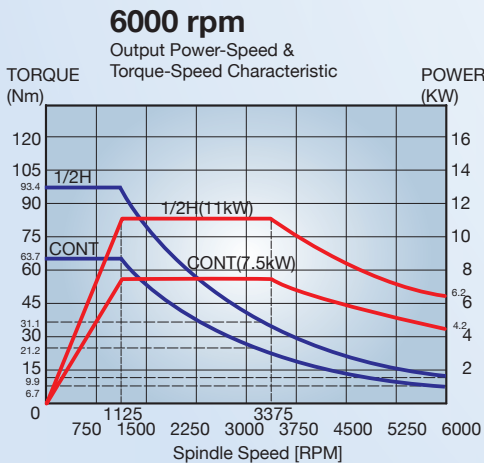

PULL STUD & TOOL SHANK DRAWING

Tool shank BT50

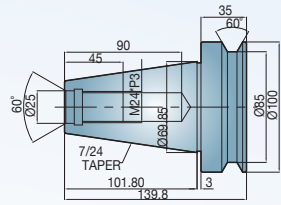

MAS-P50T-1

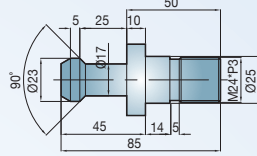

CAT50

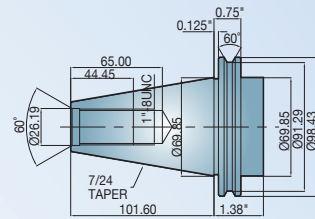

ANSI CAT50

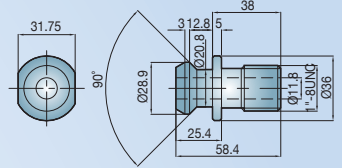

Tool shank BT40

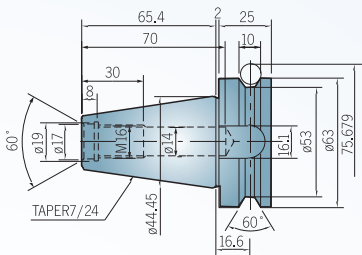

MAS-P40T-1

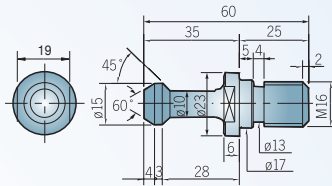

CAT40

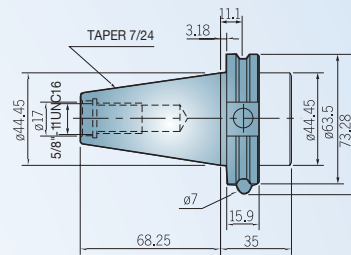

ANSI CAT40

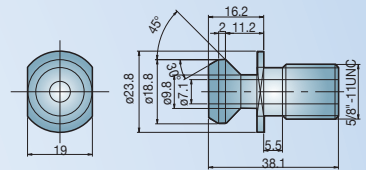

MACHINE FEATURE

24 tools arm type ATC system (Standard)



Chip flush system (Optional)

Flush nozzles provide at both side of splash guard, efficiently remove chips during operation.

Chain type chip conveyor (Optional)



CUTTING ABILITY



FACE MILLING

Work piece material	S50C
Spindle speed	920 RPM
Feedrate	1380 mm/min
Cutting width	90 mm
Cutting depth	3 mm
Material elimination rate	373 cc/min



END MILLING

Work piece material	S50C
Spindle speed	800 RPM
Feedrate	200 mm/min
Cutting width	6 mm
Cutting depth	45 mm
Material elimination rate	54 cc/min

WORK PIECE SAMPLE

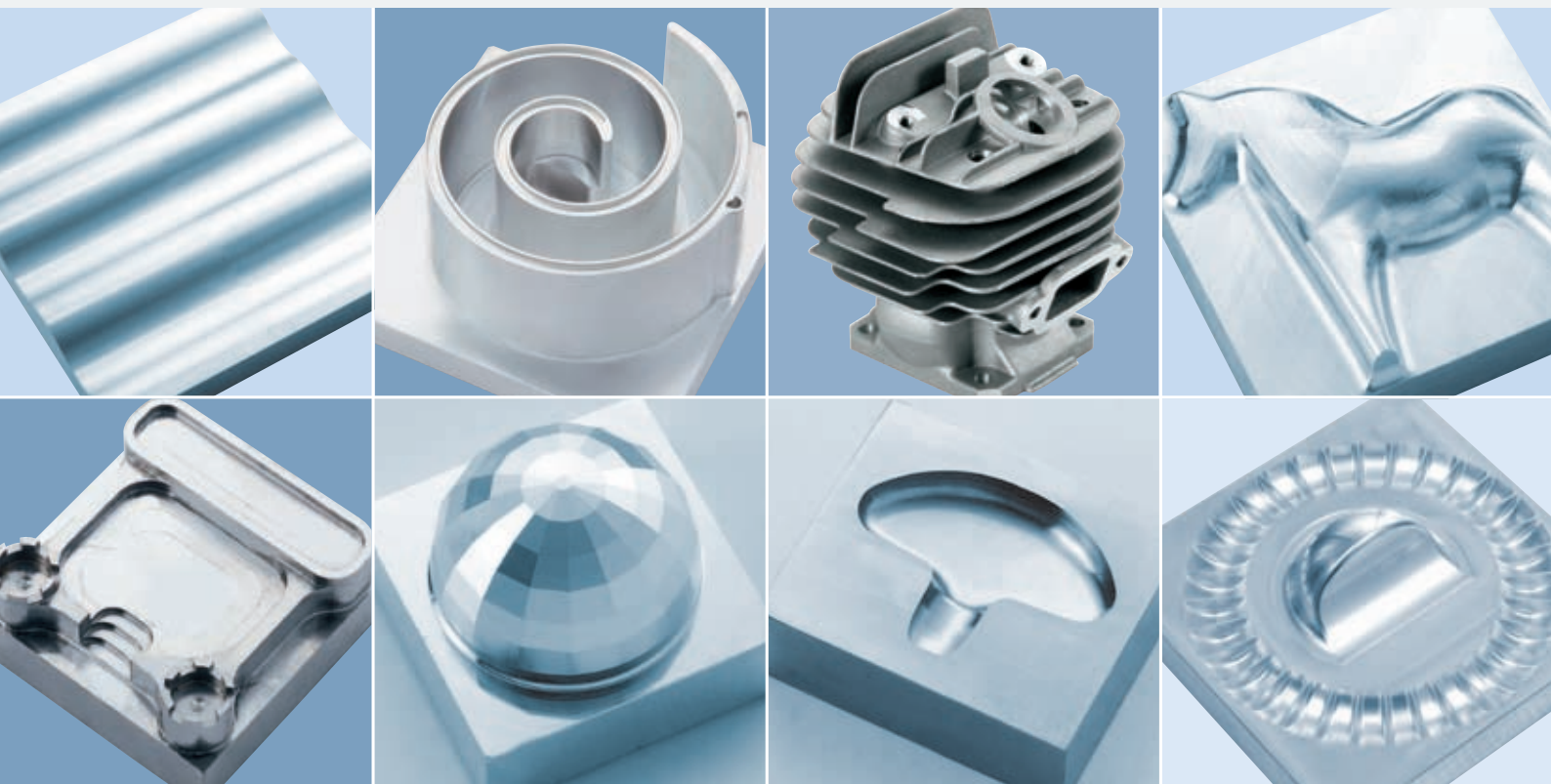

DIMENSIONAL DRAWING

Unit:mm

VP Series

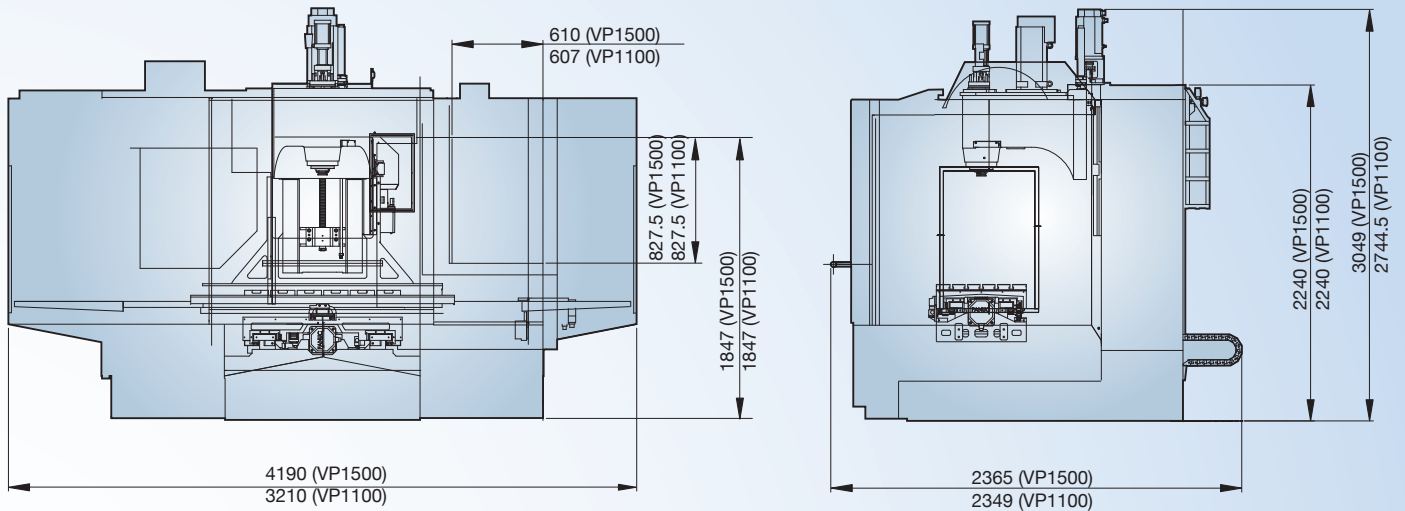

VP Plus Series (Y-Axis travels 700mm)

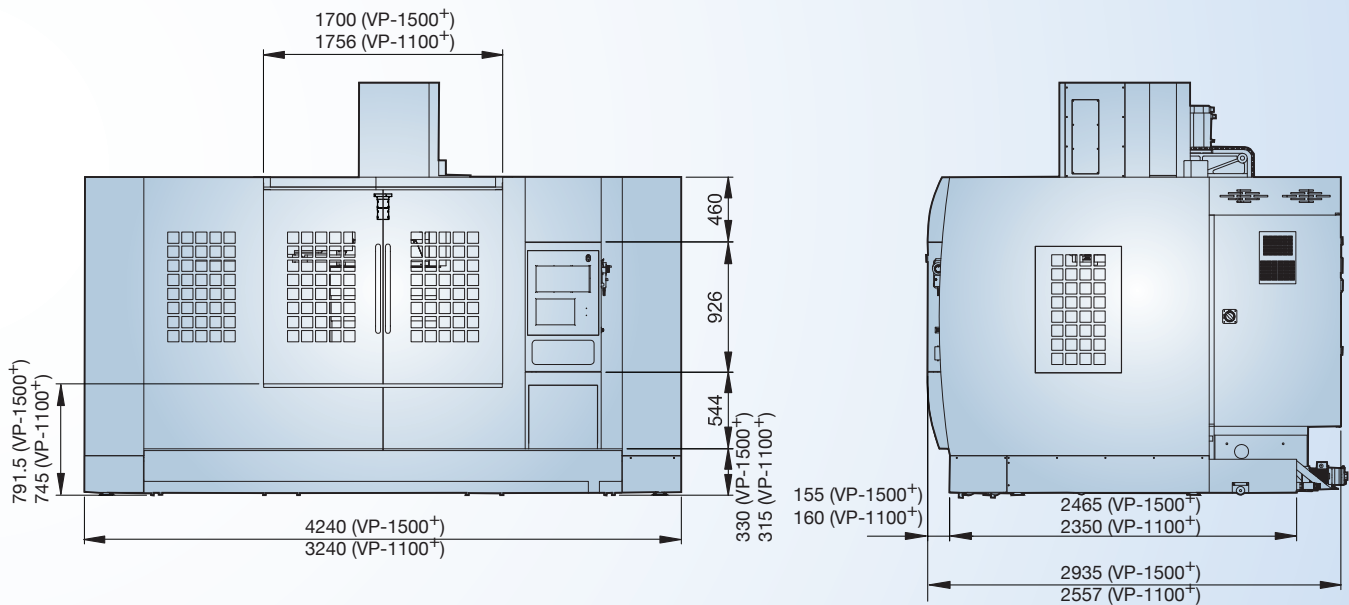

WORK TABLE DIMENSIONAL DRAWING

Unit:mm

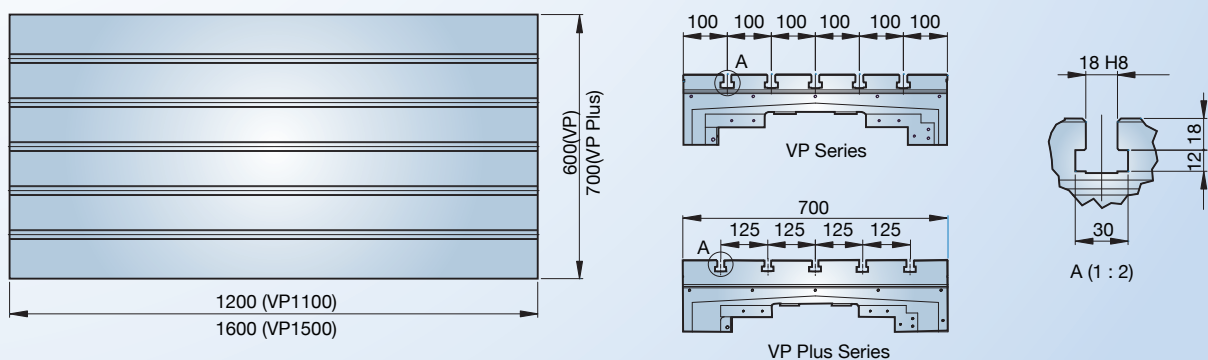

MACHINE SPECIFICATION

	VP-1100	VP-1100 ⁺	VP-1500	VP-1500 ⁺
TRAVELS				
X Axis	1100 mm		1500 mm	
Y Axis	600 mm	700 mm	600 mm	700 mm
Z Axis	600 mm			
Spindle Nose To Table Surface	150 - 750 mm			
Spindle Center To Column Front	660 mm			
Column Rail Face To Table Center	350 - 950 mm			
FEEDRATE				
Rapid Feedrate X & Y Axis	20 m/min	20 m/min	16 m/min	16 m/min
Rapid Feedrate Z Axis	20 m/min	20 m/min	16 m/min	16 m/min
Cutting Feedrate	8 m/min	8 m/min	8 m/min	8 m/min
TABLE				
Table Size	1200 x 600 mm	1200 x 700 mm	1600 x 600 mm	1600 x 700 mm
Max. Load Permissible	800 kgs			
T-Slot Number	5			
T-Slot Pitch	100 mm (VP) / 125 mm (VP+)			
T-Slot Width	18 mm			
HEAD STOCK				
Spindle Speed	8000 rpm			
Spindle Diameter	Ø70 mm			
Spindle Taper	BT-40 / CAT-40			
Spindle Motor	11 / 15 kW (Fanuc) , 7.5 / 11 kW (Mitsubishi)			
ATC				
Max. Tool Diameter(With Adj. Tool)	Ø80 mm			
Max. Tool Diameter	Ø125 mm			
Max. Tool Length	300 mm			
Max. Tool Weight	7 kgs			
GENERAL INFORMATION				
Machine Weight (Approx.)	8800 kgs	9300 kgs	9000 kgs	12000 kgs
Machine Height	2730 mm	2930 mm	2730 mm	2930 mm
Floor Space (WxDxH)	3210 x 2360 mm	3240 x 2560 mm	4170 x 2900 mm	4300 x 2935 mm
Positioning	0.005 / 300 mm			
Repeatability	±0.003 mm			
Air Pressure Required	6 kgs/cm ²			

Remark : Specification and design characteristics subject to change without prior notice.

STANDARD FEATURE

- Coolant system
- Arm type 24T ATC
- Rigid tapping
- Automatic Oil Lubricator
- Work lamp
- Heat exchanger for electrical cabinet
- Automatic power off (M30)
- Remote MPG
- Adjustment tools & tool box
- Enclosed splash guard
- Leveling bolts and pads
- Spindle air blast
- Work air blast
- RS-232 interface
- Fanuc Oi-MD or Mitsubishi M70

OPTIONAL FEATURE

- Y axis Travels 700mm
- Spindle speed 6000rpm (BT-50)
- Spindle speed 10000rpm (BT-40)
- ZF Gear box
- Coolant through spindle with filter system
- Wide range motor
- 4th axis rotary table
- Chain type chip conveyor with cart
- Spiral type chip conveyor with cart
- Transformer
- CE Specification
- Fanuc 31i-MB
- Mitsubishi M700 series
- Siemens 802D SL / 828D / 840D SL

Twinhorn[®]

CHI-FA MACHINERY MANUFACTURER CO., LTD.

NO.44-8 MING-CHUNG RD., SHENG KANG DIST.,

TAICHUNG CITY, TAIWAN

TEL:+886-4-25628747

FAX:+886-4-25614199

<http://www.twinhorn.com>

E-mail: inquiry@twinhorn.com.tw